

ACESNPD12-200Ah 12V200Ah

● Specifications

Nominal Voltage		12V
Rated capacity (10 hour rate)		200Ah
Dimensions	Length	522±2mm(20.55inch)
	Width	238±2mm(9.37inch)
	Height	218±2mm(8.58inch)
	Total Height	222±2mm(8.74inch)
Approx. Weight		59.5kg(130.90bs)±3%



● Outer dimensions (mm)

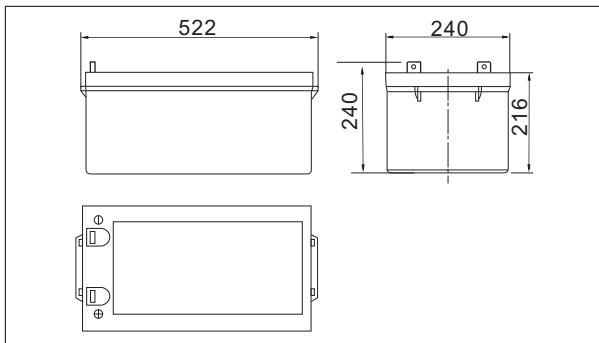

● Terminal Type (mm)

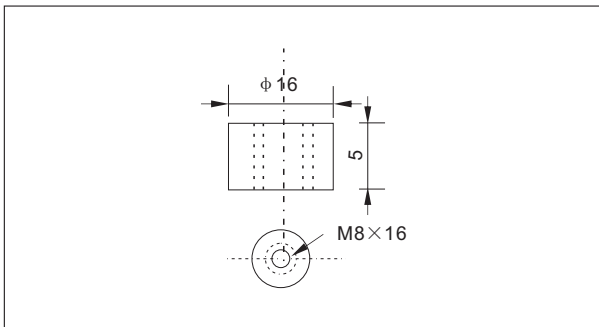

● Construction

Component	Positive plate	Negative plate	Container	Cover	Separator	Electrolyte	Safety valve	Terminal
Raw material	Lead dioxide	Lead	ABS	ABS	AGM	Sulfuric acid	Rubber	Copper

● Constant Current Discharge Characteristics Unit:A(25°C,77°F)

F.V/Time	15min	30min	60min	2h	3h	4h	5h	6h	8h	10h	20h
9.60V	336	201	124	73.1	52.6	42.0	35.9	31.2	24.7	20.4	10.8
9.90V	328	197	122	72.6	52.3	41.8	35.7	31.0	24.5	20.3	10.8
10.2V	316	191	119	72.0	52.0	41.5	35.4	30.8	24.4	20.3	10.7
10.5V	305	186	115	70.9	51.6	41.2	35.2	30.6	24.2	20.1	10.7
10.8V	289	179	111	69.1	50.1	40.0	34.1	29.7	23.5	20.0	10.6

● Constant Power Discharge Characteristics Unit:W(25°C,77°F)

F.V/Time	15min	30min	60min	2h	3h	4h	5h	6h	8h	10h	20h
9.60V	3689	2255	1409	846	619	494	424	369	293	243	129
9.90V	3601	2210	1388	841	615	491	422	367	292	243	129
10.2V	3468	2142	1353	834	611	488	419	364	290	242	129
10.5V	3350	2091	1310	821	607	485	416	362	287	240	128
10.8V	3173	2014	1268	800	589	470	404	351	279	239	127

Note: The above characteristics data can be obtained within three charge or discharge cycles.

● Characteristics

Capacity (25°C)	10HR(10.8V)	200Ah
	3HR(10.8V)	150Ah
	1HR(10.5V)	110Ah
Terminal type		T16
Internal resistance (Fully charged,25°C)		Approx.3.5m Ω
Capacity affected by temperature (10HR)	40°C	102%
	25°C	100%
	0°C	85%
	-15°C	65%
Self-discharge (25°C)	3month	Remaining Capacity:91%
	6month	Remaining Capacity:82%
	12month	Remaining Capacity:65%
Nominal operating temperature		25°C ±3°C(77°F ±5°F)
Operating temperature range	Discharge	-15°C~50°C(5°F~122°F)
	Charge	-10°C~50°C(14°F~122°F)
	Storage	-20°C~50°C(-4°F~122°F)
Float charging voltage(25°C)		13.50 to 13.80V Temperature compensation: -18mV/°C
Cyclic charging voltage(25°C)		14.50 to 15.00V Temperature compensation: -30mV/°C
Maximum charging current		60A
Terminal material		Copper
Maximum discharge current		1400A(5 sec.)
Designed floating life(20°C)		10years

ACESNPD12-200Ah 12V200Ah

● Discharge characteristics(25°C)

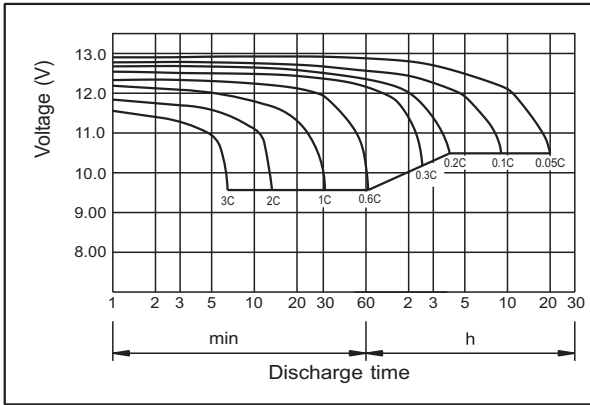

● Charging characteristics (25°C)

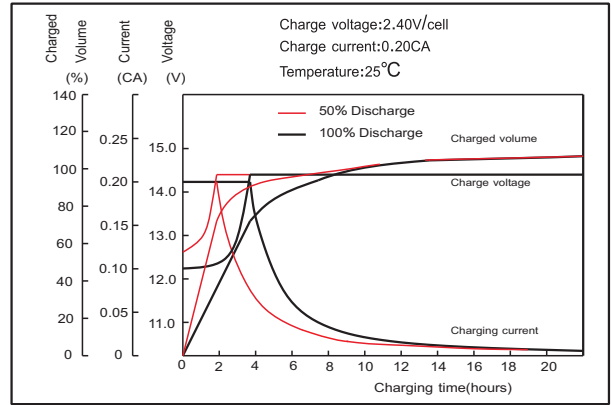

● Temperature effects on Capacity

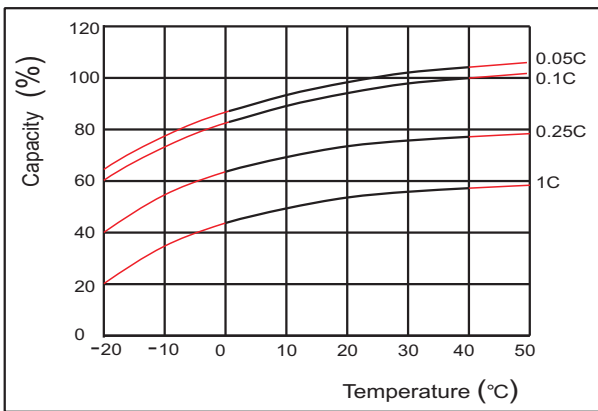

● Self-discharge characteristics

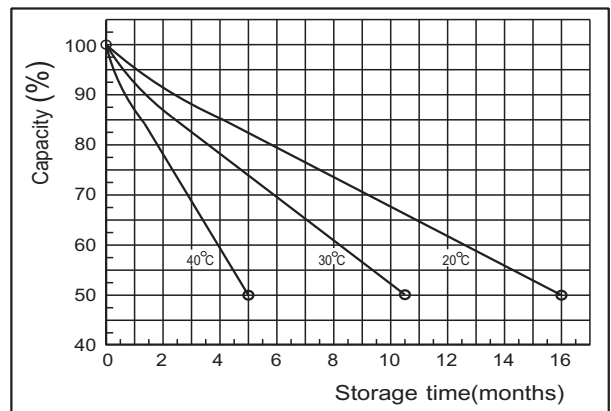

● Floating life on Temperature

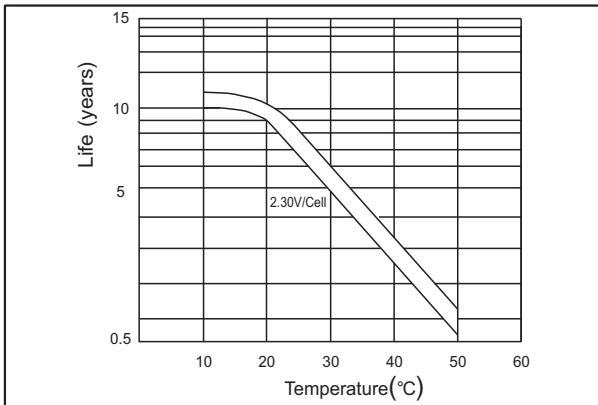

● Cycle life on D.O.D (25°C)

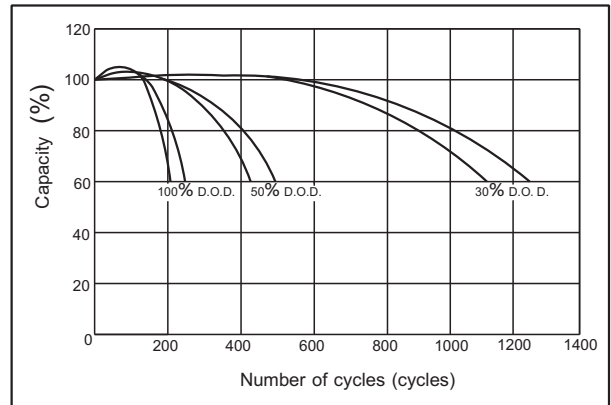

● The relationship for OCV and Capacity (25°C)

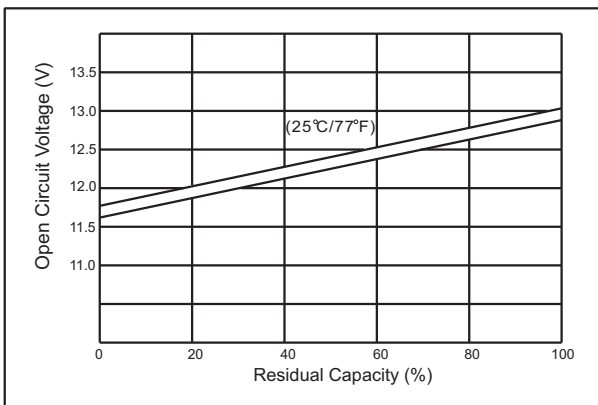

● The relationship for Charging voltage and Temperature

